

New design of brine electrolyser with a membrane and a mercury cathode

E. HERMANA, L. A. S. INFANZON*, J. CERVELLO, M. BAILE*, E. D. NOGUEIRA*

Investigación Química Industrial, S.A. c/ Arapiles, 13 Madrid-15, Spain

Received 20 December 1978

A novel brine electrolysis cell is described. It employs both a mercury cathode and a membrane and it is shown that its performance may be superior to both conventional membrane or diaphragm cells and mercury cells.

1. Introduction

Brine electrolysis for chlorine and caustic soda (or potash) production has been carried out industrially since the last quarter of the nineteenth century. The problem of a reaction between the products has been solved through the development of two main types of cell, diaphragm and mercury cathode cells. At the end of the 1950s, diaphragm cells were being replaced by mercury cells because of the higher energy efficiency, better product quality (particularly NaOH) and flexibility of this type of cell. In spite of the need to use solid salt as the raw material, it allowed economical operation over a greater range of capacities than its rival diaphragm cell.

Public awareness of the dangers of mercury pollution, with the consequent appearance of stringent levels for Hg-emission, and new developments in diaphragm technology, reversed this trend during the 1960s, despite the highly efficient techniques developed for mercury pollution abatement. In the 1960s, a new type of cell, profiting from the development of new cation semi-permeable stable membranes, was developed [1-3]. The cell should provide the product quality typical of mercury cells, remove the need for a caustic concentration stage and have the lower electrical consumption of a diaphragm cell. These cells have reached an industrial scale in Sweden, Japan and Canada but they should be considered, in some ways as pilot plants, due to their small capacity.

The present state of membrane cell technology could be summarized in three statements:

(a) A caustic solution substantially free of chloride may easily be obtained; the purity matches that from mercury cells.

(b) A compromise between cathodic current efficiency and caustic concentration must be set. Membrane modification in order to reach a greater current efficiency normally requires a higher cell voltage, and, thus, greater energy consumption.

(c) Extremely low levels of impurities in the brine must be maintained in order to avoid blocking of the membrane by insoluble hydroxide formation on the cathodic side.

In any case, if caustic soda concentrations of 50% are required, a concentration stage must be built, because cell outlet concentrations above 30% are prohibitive in energy consumption.

This paper describes the development of a new type of cell that could overcome this stalemate. It arose from the idea of combining a mercury cathode and a cation permeable membranes, and trying to profit from the best characteristics of both types of cell.

2. Cell design

A diagram of the cell scheme is shown in Fig. 1. The mercury is held between the steel cathode and the membrane. The mechanical stress from hydrostatic pressure because of the mercury is compensated by the metallic anode structure on the other side of the membrane. The mercury flows upwards, and the resulting amalgam overflows into the graphite denuder. Brine also flows upwards

* Técnicas Reunidas Investigación

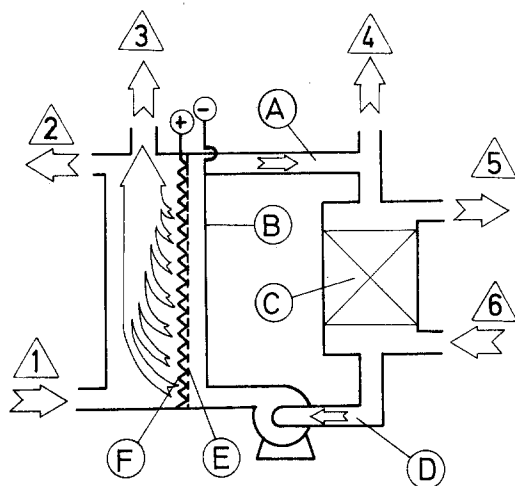

Fig. 1. Diagram of the cell scheme. A, amalgam Hg-Na; B, cathode; C, graphite denuder; D, mercury; E, cation exchange membrane; F, anode grid; 1, concentrated brine (26 wt%); 2, diluted brine (13–15 wt%); 3, chlorine; 4, hydrogen; 5, NaOH (50 wt%); 6, de-ionized water.

through the anodic compartment and along with the chlorine produced, this provides a lifting force for the brine flow.

The electrolyser will consist of a number of these unit cells, with brine and mercury circuits arranged in parallel, all of them sharing a common amalgam denuder. This type of cell and arrangement of the array of cells should have the following advantages, as compared with the standard horizontal mercury cells:

- (a) No shortcircuiting, because of the membrane separating the anode and cathode.
- (b) Constant interelectrode gap, permanently defined by the membrane thickness (as low as 0.1 mm).
- (c) No need for a mechanism for anode position adjustment, as a direct consequence of (a) and (b).
- (d) Continuous separation of hydrogen and chlorine, since they are produced on different sides of the membrane. Hence there is no risk of explosion in the case of low cathodic current efficiency.
- (e) Greater electrode surface area per unit of floor surface, thus allowing: (i) possible reductions in investment, for a given capacity; (ii) economical operation using lower current densities than in horizontal cells; (iii) lower cell voltage, as a consequence of (ii); (iv) energy consumption savings, as a consequence of (iii).

(f) Longer anode life, as a consequence of the possibility of operating at lower voltages and no damage from shortcircuiting.

(g) No bother from Hg butter formation, since it is continuously pushed out of the cells by the higher density mercury flow.

(h) Operation with a higher depletion of salt concentration, since a lower current efficiency can be tolerated, due to (d). This involves a reduction in the amount of brine to be processed.

(i) Reduction of mercury pollution, since (i) no mercury passes across the membrane, and consequently the brine circuit will be free of it; (ii) long operation periods will reduce the loss of mercury due to air emission spillages and discontinuities.

(j) Higher current efficiency, due to the direct separation of products, as compared with horizontal mercury cells.

Membranes to be used in this type of cell must have four properties;

(a) Good permeability to Na^+ or K^+ ions, thus allowing for a low cell voltage.

(b) Porous structure with maximum pore size given by

$$r = \frac{0.75 \times 10^{-1}}{\Delta P} \text{ mm} \quad (1)$$

r being the pore radius, and ΔP the hydrostatic pressure difference between the two sides of the membrane (in N cm^{-2}).

(c) Good mechanical strength, able to withstand the hydrostatic pressure of the mercury.

(d) Chemical stability of the membrane in the brine electrolysis conditions.

The other usual requirements (e.g. low permeability to OH^- ions) have no significant importance for the Memmer design.

We have tested several types of Nafion* membranes, supplied by Du Pont de Nemours. All of them have shown good performances for conditions (b–d) whether reinforced with Teflon mesh or not.

The performance of the membranes with respect to (a) depends on their thickness (0.1–0.25 mm) and their equivalent molecular weight (1100–1500). The cell voltage is directly dependent on the values of these two characteristics.

* Registered trade mark by Du Pont de Nemours.

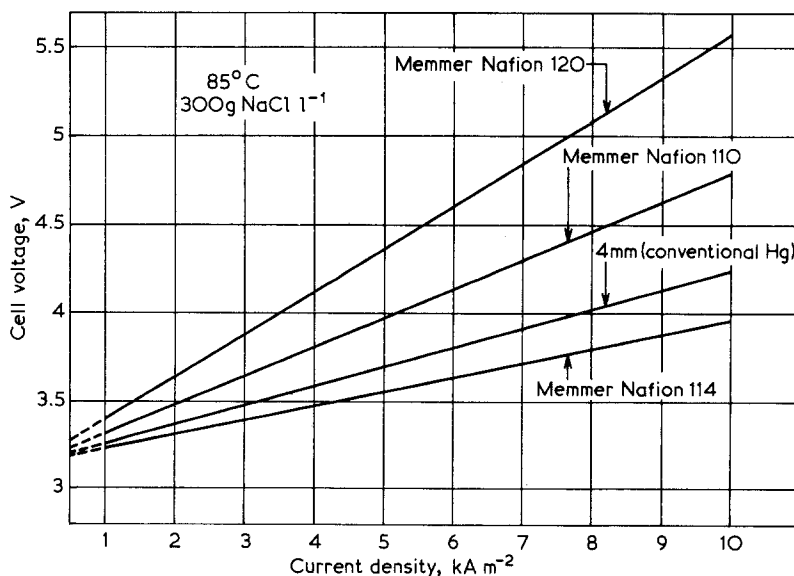

Fig. 2. Plot of the cell voltage as a function of current density for three types of Nafion membrane.

3. Cell operation

Early testing of the membranes was carried out in a 8 cm diameter cylindrical cell, built in Teflon, with experimental facilities able to supply 30 A of direct current. Some heating equipment was provided for the brine and mercury circuits to control the operating temperature on both sides of the membrane.

A steel plate on the mercury side was used as the cathode current collector. The brine and mercury flows could be varied up to 200 ml min⁻¹ and 300 ml min⁻¹, respectively. The volumes for the anolyte and catholyte were 200 and 20 cm³. A titanium anode with a noble metal oxide coating was used.

Fig. 2 shows the cell voltage as a function of current density for three types of Nafion membrane. Nafion no. 120 has 1200 EW and 0.25 mm thickness. Nafion nos. 110 and 114 have 1100 EW, and thicknesses 0.25 mm and 0.1 mm, respectively.

Table 1

Membrane no.	Slope [V/(kA m ⁻²)]
120	0.24
110	0.17
114	0.08
no membrane, 4 mm gap	0.12

For comparison a line is shown for a conventional horizontal mercury cell, without membrane, with an interelectrode gap of 4 mm.

The results show the possibility of operation with membrane no. 114 at lower voltages than those from horizontal cells, at all values of current density. Lower cell voltage may also be reached with the other two membranes, if a substantial reduction in current density could be achieved. As it will be shown later, the compact design of the cell allows for such a reduction.

The values of the slopes of these lines, a

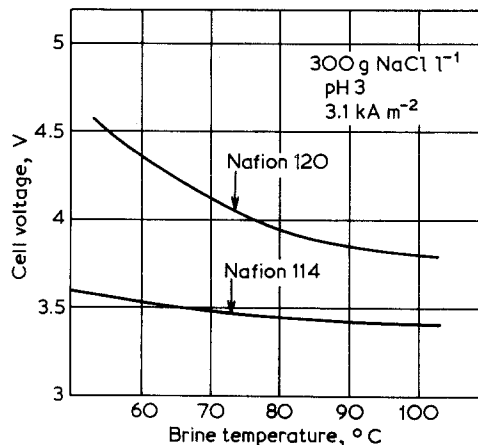

Fig. 3. Plot of the temperature dependence with constant current density.

Table 2. Memmer electrolyser effect of pH on current efficiency (300 g l⁻¹ NaCl, 35° C, 3.1 kA m⁻²)

Feed pH	Current efficiency for NaOH (%)	Current efficiency for Cl ₂ (%)
2.1	97	98
4.3	97	98
5.9	96.9	98.5

traditional way for measuring cell performance, are shown in Table 1.

These results were obtained at 85° C. The temperature dependence for one value of current density is shown in Fig. 3. It emphasizes that the energy consumption of the cell is strongly dependent on the operating temperature with Nafion 120. A relatively constant value for Nafion 114 suggests that the Memmer electrolyser could be operated at relatively low temperatures.

Table 2 shows the effect of pH on both cathodic and anodic current efficiency. These are clearly independent of pH. It must be recalled that horizontal mercury cells cannot operate at pH values below 2–3 because of the high rate of hydrogen formation, or above 5–6 because of the high rate of chlorate production. Current efficiency for the nos. 110 and 114 membranes are similar to these data and are in the 96–99% range.

Results from this scale of operation with Nafion 120 are compared, on a voltage versus current density plot, with published results from commercial and development cells in Fig. 4. A dotted zone indicates the operating region for

industrial cells. It shows the possibility of operating a Memmer cell with cell voltages competitive with other designs.

4. Pilot scale electrolyser

A 3 kA Memmer electrolyser, designed in mid-1976 on the basis of these results, is shown in Fig. 5. It consists of four 50 cm × 25 cm unit cells, with brine and mercury flows parallel and upward, in a monopolar electrical array.

This model has been operating for a year, testing different gaskets, procedures, building materials and anode design, as well as the effect of operating conditions.

The design characteristics of this model are:

number of elemental cells	4
electrode height	50 cm
electrode width	25 cm
mercury thickness layer	6 mm
unit cell width	3.6 cm
$\frac{\text{electrode surface}}{\text{floor surface}}$	= 11.5

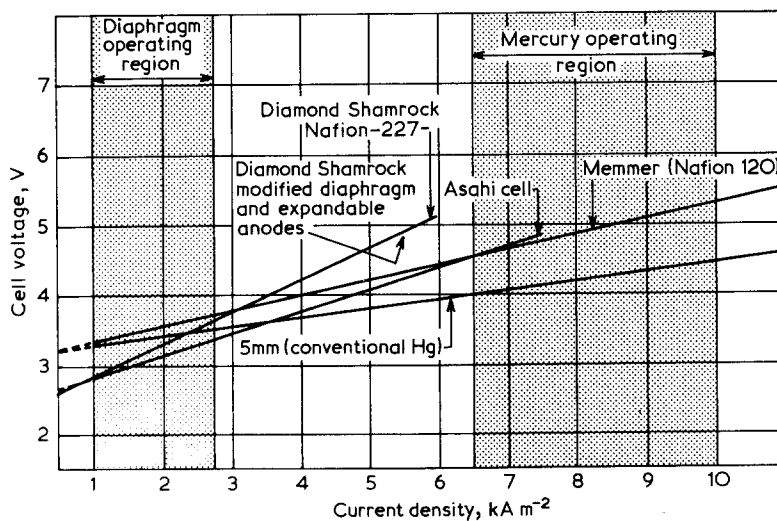

Fig. 4. Plot of voltage versus current density, also showing published results for some commercial cells.

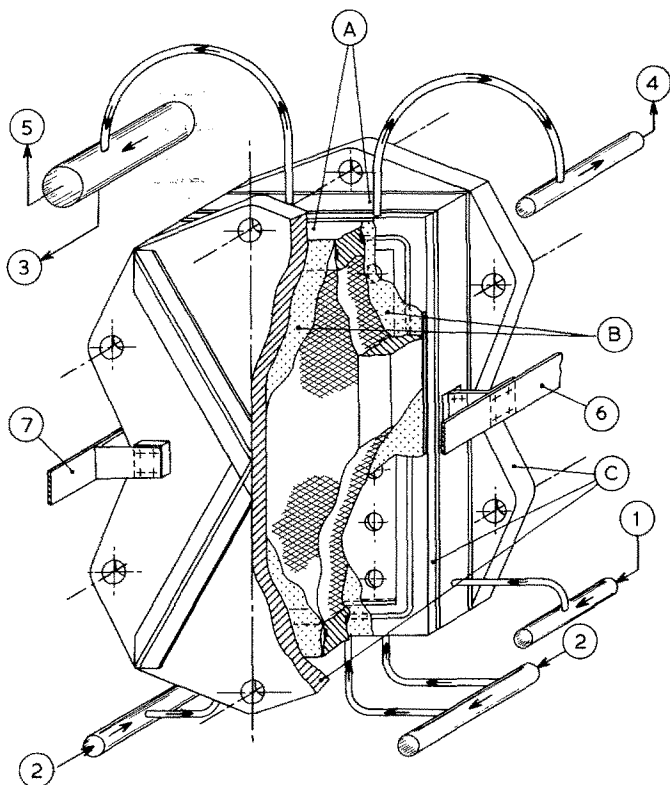

Fig. 5. A 3 kA Memmer electrolyser model. A, anode compartment; B, membrane; C, cathode; 1, brine inlet; 2, mercury inlet; 3, brine outlet; 4, amalgam outlet; 5, chlorine outlet; 6, anode busbar.

The value of the electrode surface per unit of floor surface should increase linearly with the height of the cell. From data on the mechanical resistance of

the membranes, a height of 100 cm is a safe height for future industrial electrolyzers, which raises this ratio to 23. This value indicates the compact

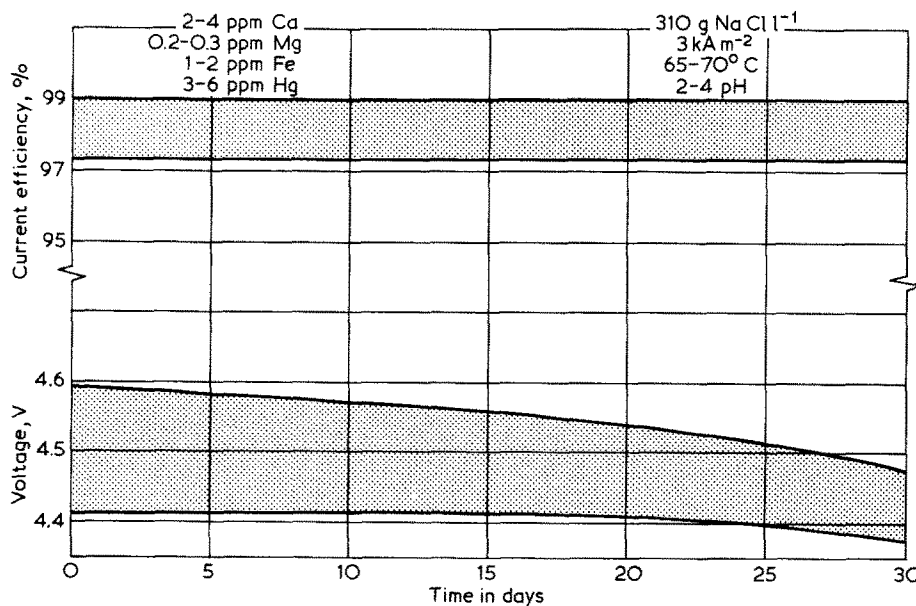

Fig. 6. Results from 30 days continuous operation of the Memmer electrolyser model. The two bands represent the variation in cathodic current efficiency and cell voltage.

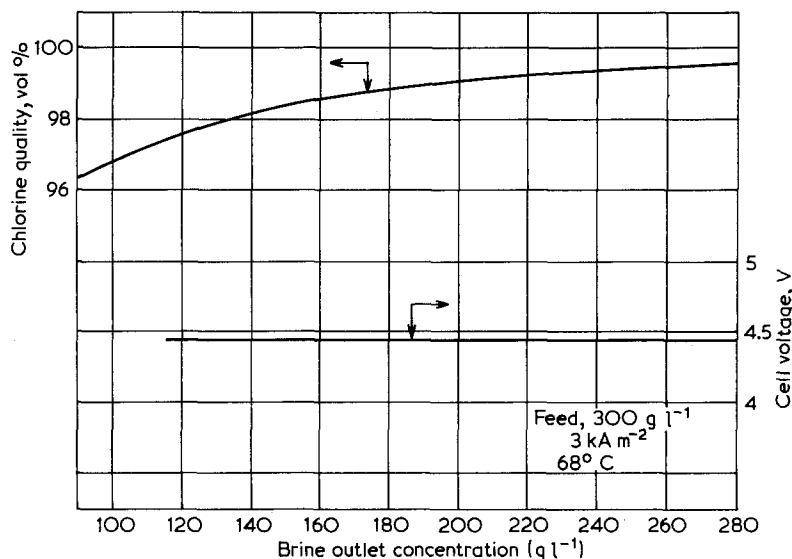

Fig. 7. Plot of cell voltage and chlorine concentration in the gas stream versus outlet brine concentration for the Memmer cell.

design of this cell, as compared with the horizontal cells, and allows a reduction in the current density for the same production/floor requirement. Investment costs cannot be compared at this stage.

Fig. 6 shows the results from 30 days of continuous operation of this model. The two bands represent the variation in cathodic current efficiency and cell voltage.

The higher values of cell voltage than expected on the basis of the data in Fig. 3 are due to lower mercury temperatures, in the 50–60°C range. A slight increase in temperature during operation explains the bending down of the voltage band during later days. Salt depletion was held at 60 g l⁻¹ for this test. Brine purification was con-

stantly performed by an exclusive IQI procedure, the Samex process, involving selective liquid-liquid cationic extraction [4].

The results indicate that a relatively high level of impurities, can be tolerated by the membrane with this design. More precise data on the dependence of membrane operating life on the brine impurity level require more prolonged work. The mercury impurities are due to spilling during the initial procedures. No significant increase was detected during operation.

The Memmer cell performance during operation under conditions of high salt depletion from brine is shown in Fig. 7. Cell voltage and chlorine concentration in the gas stream are plotted versus the

Table 3. Performance of several chlorine cell models (data taken from [3])

Cell model	Operating voltage (V)	Current density (kA m ⁻²)	Current efficiency (%)	Energy consumption (kW h/ton Cl ₂)	Floor area (m ² /10 ³ ton Cl ₂ per year)	
					Electrolysis*	Electrolysis + soda concentration
Mercury De Nora 24 M2	4.3	10	96.5	3373	25	25
Diaphragm Glanor	3.6	2	96	2840	7	43
Membrane Asahi chemical	3.75	4.2	93	3052	22	25
Memmer IQI	3.7	3	98	2858	8	8

* A ratio floor area/cell area = 3 has been estimated.

outlet brine concentration. The feed contained 305 g l^{-1} . These results suggest that a much greater salt depletion than is possible with a horizontal cell can be achieved without significant energy loss. 7.6 m^3 of brine would suffice for producing one ton of chlorine, when brine is depleted to the 90 g l^{-1} level, with only 8% loss in energy. This should be compared with the $50\text{--}80 \text{ m}^3/\text{ton Cl}_2$ required in some modern horizontal cells. This fact raises the possibility of employing brine directly mined from underground salt deposits, thus eliminating the traditional mercury cell dependence on a solid salt supply.

5. Conclusions

We conclude, from these results, that most of the possibilities suggested for the Memmer cell design have been fulfilled. Without knowledge of the maximum time of continuous operation, and the maximum permitted levels of impurities in the brine, a number of advantages may be claimed compared with horizontal mercury cells. Additional advantages over diaphragm and mem-

brane cells are similar to the standard mercury cells.

An industrial prototype, able to operate in a chlorine cell line (250 kA) is under design and construction. It is expected to commence operation in October 1979.

Assuming industrial results similar to the 3 kA model, a comparison of this hypothetical performance with published results for the most relevant models of the other cells is shown in Table 3. An intermediate value of cell voltage between results from membranes nos. 120 and 114 has been used.

These results show clearly the possibilities for the Memmer electrolyser as an alternative for chlorine production in the near future.

References

- [1] W. Grot, *141st National Meeting Electrochem. Soc.* Houston, May (1972).
- [2] Belgian patent no. 790 369, Diamond Shamrock (1973).
- [3] M. Seko, *Ind. Eng. Chem. Prod. Res. Dev.* **15** (1976) 286.
- [4] E. D. Nogueira *et al.*, *Chlor-alkali Technology Symposium*, London (1979).